



aerospace  
climate control  
electromechanical  
filtration  
fluid & gas handling  
**hydraulics**  
pneumatics  
process control  
sealing & shielding



## Bladder Accumulators

EBV - ELG from 20 to 80 bar



ENGINEERING YOUR SUCCESS.

# Main Features

## Operation principle

Operation of the Parker Olaer gas loaded bladder accumulator is based on the considerable difference in compressibility between a gas and a liquid, enabling a large quantity of energy to be stored in an extremely compact form. This enables a liquid under pressure to be accumulated, stored and recovered at any time. Its special design allows the bladder (the strategic component) to compress the gas and usually form into three lobes in order for the accumulator to store, then to deliver the fluid under pressure, as required.

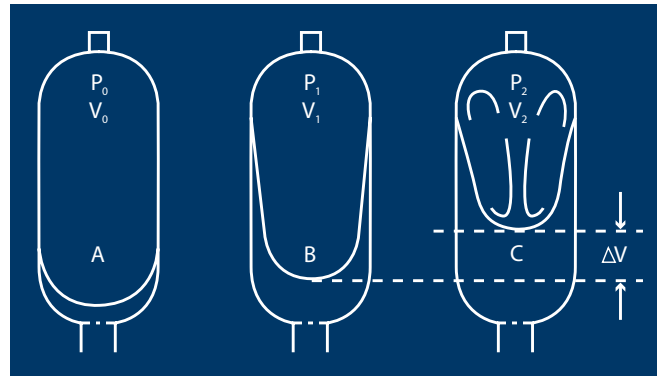

<b>V<sub>0</sub></b> = Nitrogen capacity of the accumulator	<b>P<sub>0</sub></b> = Initial preload of the accumulator
<b>V<sub>1</sub></b> = Gas volume at the minimum hydraulic pressure	<b>P<sub>1</sub></b> = Gas pressure at the minimum hydraulic pressure
<b>V<sub>2</sub></b> = Gas volume at the maximum hydraulic pressure	<b>P<sub>2</sub></b> = Gas pressure at the maximum hydraulic pressure
<b>ΔV</b> = Returned and/or stored volume of working fluid between P <sub>1</sub> and P <sub>2</sub>	

**A** - Bladder in the pre-charge position, which means that it is only filled with nitrogen. The anti-extrusion system perforated bushing closes the hydraulic orifice and prevents the destruction of the bladder. *Maximum pressure differential (P<sub>2</sub>/P<sub>0</sub>): 4:1*

**B** - Position at the minimum operating pressure ; there must be a certain amount of fluid between the bladder and the hydraulic orifice, such that the anti-extrusion system does not close the hydraulic orifice. Thus, P<sub>0</sub> must always be < P<sub>1</sub>.

**C** - Position at the maximum operating pressure. The volume difference  $\Delta V$  between the minimum and maximum positions of the operating pressures represents the working fluid quantity.

## Your Benefits

For flows greater than 130 m<sup>3</sup>/h in the networks, the EBV accumulator absorbs overpressures and compensates for pressure reductions generated by fast valve closures.

### For example:

- Unleaded gasoline network
- Maximum network pressure = 10 Bar
- Feed : three 130 m<sup>3</sup>/h pumps at 4 Bar
- Valve closure in 3s.

### Results:

- Without accumulator: P<sub>min</sub> = -1 Bar / P<sub>max</sub> = 14 bar
- With EBV accumulator 100-40/90 01180  
P<sub>min</sub> = 2.5 bar / P<sub>max</sub> = 8 Bar

### The pre-charge pressure must NOT exceed 20 bar

When starting pumps on a pressurised network, the overpressure generated by “putting the fluid mass into circulation” is compensated by the EBV accumulator. The EBV and ELG accumulator ranges conform with the new EC regulations.

## Technical Characteristics

The accumulator comprises of a pressure vessel including valve stem device, a rubber bladder and an anti-extrusion system.

- Shell material options include alloyed steel, stainless steel, aluminium, titanium and composites.
- Various bladder materials available which are compatible with a range of fluids and temperatures.
- Anti-extrusion system; perforated bushing.

Taking into account the different needs of various applications, Parker Olaer offers different protections external and/or internal: Bare metal, nickel plating, epoxy paint, PTFE, Rilsan® and phenolic coating. This extensive range enables us to offer accumulators operating from - 40 to +130°C with pressures of up to 80 Bar and capacities of up to 575 litres. ATEX versions are also available for some accumulators in fluid groups 1 or 2 as per Article 9 section 2.1 and 2.2 of PED.

As the market leader in bladder type accumulators, Parker Olaer has participated in the development of the EN 14359:2006 standard, which specifies the material, design, manufacturing, fatigue tests, safety devices and documentation (including the instruction manual), for pressure accumulators and gas bottles for hydraulic applications.

# How to size?

OLAER has developed software to design accumulators to absorb the shock. You can use two different procedures to evaluate and to find a shock absorber solution with guaranteed results\*.

\*(complete procedure and send this to Parker Olaer)

	Procedure
	Complete      Partial
• Pressure readings and validation of assumptions on site	_____ <input checked="" type="checkbox"/> <input type="checkbox"/>
• Shock absorber calculation starting from a correctly filled in questionnaire with isometric drawing (supplied by you)	_____ <input checked="" type="checkbox"/> <input checked="" type="checkbox"/>
• Validation of calculations on site by pressure readings after installation of the selected accumulators	_____ <input checked="" type="checkbox"/> <input type="checkbox"/>

**Formular to return**

Company : ..... Service : ..... Name : .....

Phone : ..... E-mail : ..... Fax : .....

I want : (tick the appropriate box)     A complete procedure     A partial procedure

**Your installation**

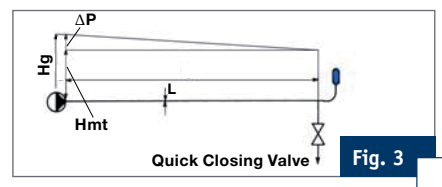
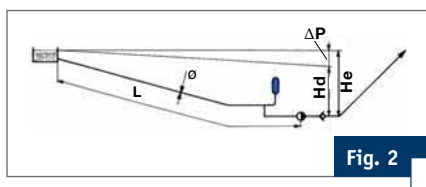
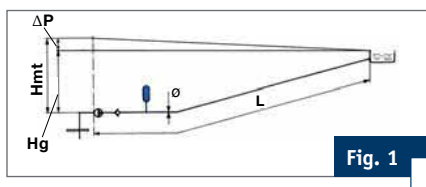

Your installation (tick the appropriate box)

Hmt : Total pressure head - Hg : geometric head - ΔP : Pressure loss - Ø : Pipe diameter - Hd : Intake head - He : Static head

**Application type (fill in according to your installation)**

Starting and stopping the pump (fig. 1)      Pump stop time (secondes) : .....

Pressurised intake (fig. 2)      Pump stop time (secondes) : .....

Closes valves (fig. 3)      Valves closure time (secondes) : .....

Fluid : .....      ..... L/mn

Pipe material : .....      Max.flow rate at valve closure : ..... L/mn

Pipe length (L) : ..... m      Total pressure head (Hmt) : ..... Mcl

Pipe inner diameter (Ø) : ..... mm      Geometric head (Hg) : ..... Mcl

Pipe thickness : ..... mm      Intake head (Hd) : ..... Mcl

Max. flow rate of the pump : .....      Static head (He) : ..... Mcl

**Plumbing sector**

Table provided for guidance, valid for a residual fluid pressure of about 3 bar at the end of the column and for a flow speed in the pipe of 2.5 m/s max. Pre-charge pressure equivalent to the residual pressure at the end of the column. Pre-charge done by us at the factory outlet.

Pipe Ø	Pipe length or height (m)		
	10-20-30	40-50-60	70-80-90
8/13	OLG 0.13-50/00 01925	OLG 0.13-50/00 01925	OLG 0.13-50/00 01925
15/21	OLG 0.13-50/00 01925	OLG 1-20/00 03325	OLG 1-20/00 03325
20/27	OLG 0.13-50/00 01925	OLG 1-20/00 03325	OLG 1-20/00 03325
26/34	OLG 1-20/00 03325	OLG 1-20/00 03325	ELG 4-20/90 01925
33/42	OLG 1-20/00 03325	ELG 4-20/90 01925	ELG 4-20/90 01925
40/49	OLG 1-20/00 03325	ELG 4-20/90 01925	ELG 4-20/90 01925
50/60	ELG 4-20/90 01925	ELG 4-20/90 01925	Consult Olaer

# Technical Characteristics

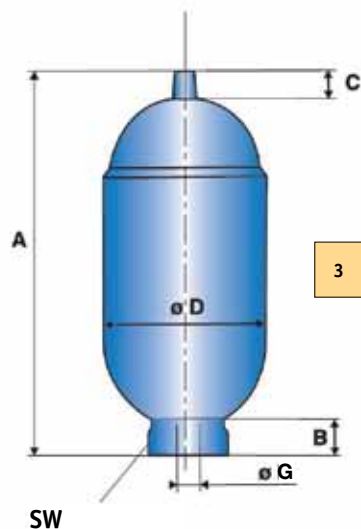
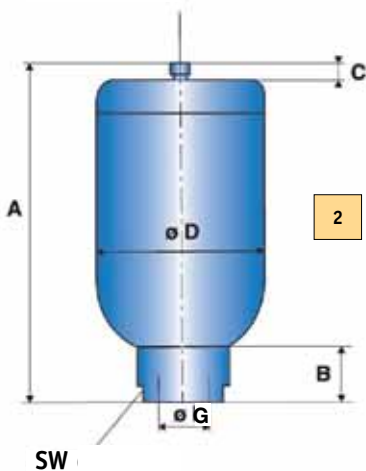
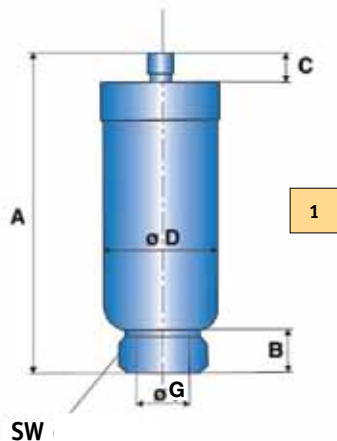

	1	2	3
<b>Type</b>	<b>OLG 0.13-50/00</b>	<b>OLG 1-20/00</b>	<b>ELG 4-20/90</b>
Max. pressure in bar	50	20	20
Nominal gas volume in litres	0.13	1	3.8
Weight in kg	0.3	1.6	3.7
ø D maxi	50	107	155
A max height	136	210	340
Connection ø G	G 3/4" cyl.	G 1" cyl.	<span style="border: 1px solid black; padding: 0 2px;">4</span> G 2" cyl.
ø spot facing x depth	33 x 0.5	-	73 x 1.5
B	16	31	40
C	13	11	16
SW	6 flats 36 A/F	2 flats 46 A/F	2 flats 82 A/F
P/N clamps x (quantity)	-	E 106 x 1	E 155 x 1

- 1 According to the PED, article 3.3 stainless steel
- 2 According to the PED, article 3.3
- 3 According to the PED, article 3.3 stainless steel
- 4 Possibility with connection G 3/4" cyl.

Above dimensions are in mm and are subject to manufacturing tolerances.

## EBV Range from 0.5 to 5 Litres - Standard Construction

Type	Effective Gas vol. Litres	Work pressure (PS) bar	Weight in kg	Clamps x (quantity)	O-ring ø int x ø tore	Support bracket	Fittings & Flanges	Dimensions in mm						
								A max height	B	C	øD max	ød	øH	øG connection
EBV 0.5-50/00*	0.5	50	3	E95	54x3	-	consult page 8	245	52	28	90	16	68	G 2" cyl.
EBV 1-80/00*	1	80	5	E114		CE 89		310	47	66	116	22.5	68	G 2" cyl.
EBV 2.5-80/90	2.3	80	10	E114		CE 89		484	47	66	116	22.5	68	G 2" cyl.
EBV 5-80/90	5	80	17	E114		CE 89		867	47	66	116	22.5	68	G 2" cyl.

\* According to the PED, article 3.3

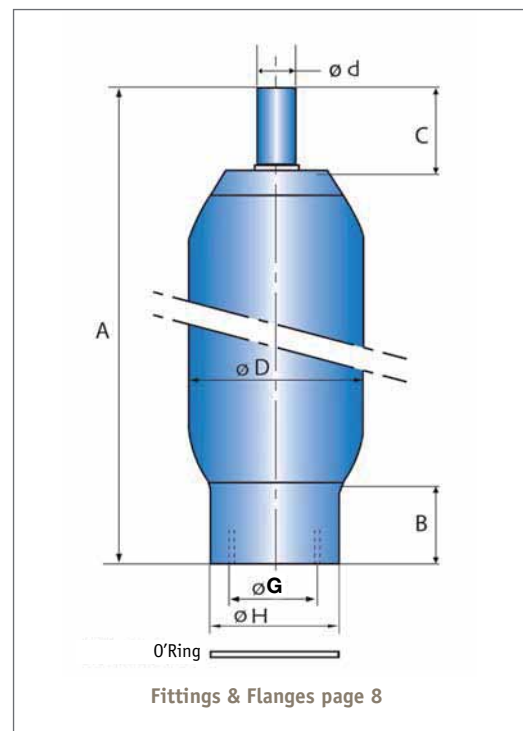

## Stainless Steel Construction

Type	Effective Gas vol. Litres	Work pressure (PS) bar	Weight in kg	Clamps x (quantity)	O-ring ø int x ø tore	Support bracket	Fittings & Flanges	Dimensions in mm						
								A max height	B	C	øD max	ød	øH	øG connection
EBV 0.5-40/00*	0.5	40	1.2	E95	54x3	-	consult page 8	246	52	30	91	16	70	G 2" cyl.
EBV 1-40/00*	1	40	1.7	E106		CE 89		312	52	75	110	22.5	70	G 2" cyl.
EBV 2.5-40/90	2.5	40	3.5	E106		CE 89		486	51	75	109.5	22.5	70	G 2" cyl.
EBV 5-40/90	5	40	6.5	E106		CE 89		869	51	75	109.5	22.5	70	G 2" cyl.

\* According to the PED, article 3.3

Above dimensions are in mm and are subject to manufacturing tolerances.

## EBV Range from 10 to 200 Litres

**Construction:** 1 Standard steel & Stainless steel version - 2 Stainless steel version - 3 Standard steel version  
 This range is also available in ATEX construction Category 2

Type	Effective Gas vol. Litres	Work pressure (PS) bar	Weight in kg	Clamps x (quantity)	O-ring $\varnothing$ int x $\varnothing$ tore	Support bracket	Fittings & Flanges	Flow max l/min	Construction	Dimensions in mm						
										A max height	B	C	$\varnothing$ D max	$\varnothing$ d	$\varnothing$ H	$\varnothing$ G connection
EBV 10-40/90	10	40	13	D215x2	96x4	CE 159A	consult Parker Olaer	900	1	454	51	75	212	22.5	120	G3½" cyl.
EBV 20-40/90	18	40	22	D215x2	96x4	CE 159A		900	1	774	51	75	212	22.5	120	G3½" cyl.
EBV 32-40/90	34	40	37	D215x2	96x4	CE 159A		900	1	1307	51	75	212	22.5	120	G3½" cyl.
EBV 50-40/90	50	40	51	D215x2	96x4	CE 159A		900	1	1829	51	75	212	22.5	120	G3½" cyl.
EBV 100-20/90	90	20	92	D368x2	196.21x5.33	CE 300		3000	2	1317	158	93	371	80	224	M205x3
EBV 100-40/90	90	40	110	D368x2	196.21x5.33	CE 300		3000	2	1319	158	93	371	80	224	M205x3
EBV 100-40/90	90	40	124	D368x2	196.21x5.33	CE 300		3000	3	1318	158	93	371	80	224	M205x3
EBV 200-20/90	202	20	171	D368x2	196.21x5.33	CE 300		3000	2	2528	158	93	371	80	224	M205x3
EBV 200-40/90	202	40	215	D368x2	196.21x5.33	CE 300		3000	3	2529	158	93	371	80	224	M205x3
EBV 200-40/90	202	40	205	D368x2	196.21x533	CE 300		3000	2	2530	158	93	371	80	224	M205x3

## EBV Range from 100 to 575 Litres

Type	Effective Gas vol. Litres	Work pressure (PS) bar	Weight in kg	O-ring $\varnothing$ int x $\varnothing$ tore	Dimensions in mm							
					A max height	B	C	$\varnothing$ D max	D	E	S	T
EBV 100-20/90	93	20	145	196.21 x 5.33	824	244	-	561	291.5	255	430	350
EBV 150-20/90	139	20	170		1027	345,5	-	561	373	295	430	350
EBV 200-20/90	207	20	208		1326	465	752	561	600	295	200	120
EBV 300-20/90	293	20	253		1702	522	1128	561	668	295	200	120
EBV 375-20/90	379	20	300		2083	522	1509	561	1049	295	200	120
EBV 475-20/90	473	20	350		2497	522	1923	561	1463	295	200	120
EBV 530-20/90	532	20	380		2756	522	2182	561	1722	295	200	120
EBV 575-20/90	565	20	400		2905	522	2231	561	1871	295	200	120

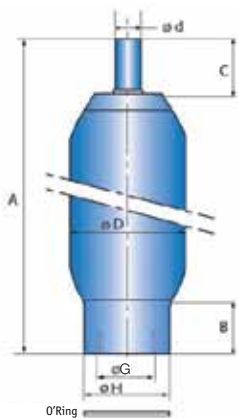

100 and 150 Litres 20B

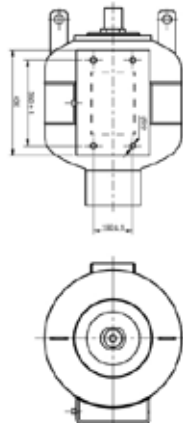

200 up to 575 Litres 20B

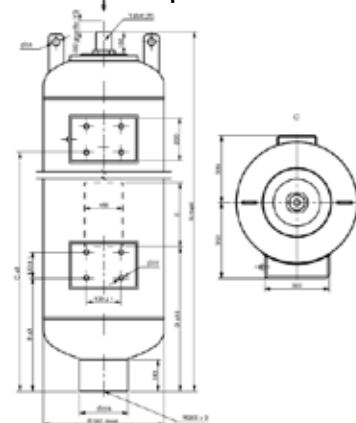

Above dimensions are in mm and are subject to manufacturing tolerances.

# Accessories

## Clamps

Type	Shape	Recommended min/max tightening diameter	Dimensions in mm												Recommended tightening torque N.m.
			A	B	C		D	E	F	G	H	I	J	K	
					Min	Max									
E95	E	87/97	88	140	61.5	66.5	1.5	28	M8x75	3	40	35	9	155	7
E106	E	99/109	88	140	68	73	1.5	28	M8x75	3	40	35	9	155	7
E114	E	112/124	88	140	73	78	1.5	28	M8x75	3	40	35	9	155	7
E155	E	146/157	137	189	81	86.5	1.7	30	M10x80	3	45	35	9	210	10.5
D215	D	215/219	210	222	123	125	3	36	M12x70	3	40	21	15	266	9
D368	D	368/372	334	346	198.5	201	3	36	M12x75	3	50	21	15	420	11

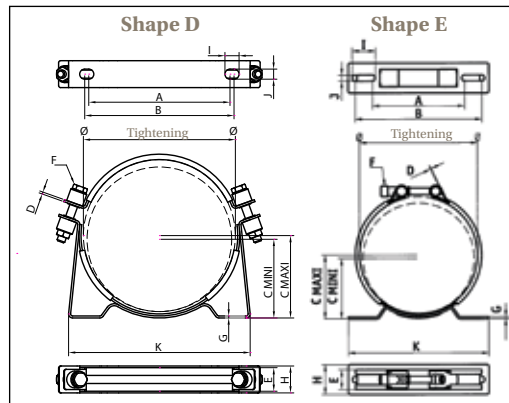

## Support Brackets

Type	A	B	C	H	I	J	K	L	M	N	R	S	Weight
CE 89	89	101	125	73	140	75	13	25	60	75	130	-	0.8
CE 159A	159	170	200	123	235	115	17	25	100	200	260	40	2.9
CE 300*	300	-	-	200	380	-	20	50	300	375	475	200	30

\* Without rubber part

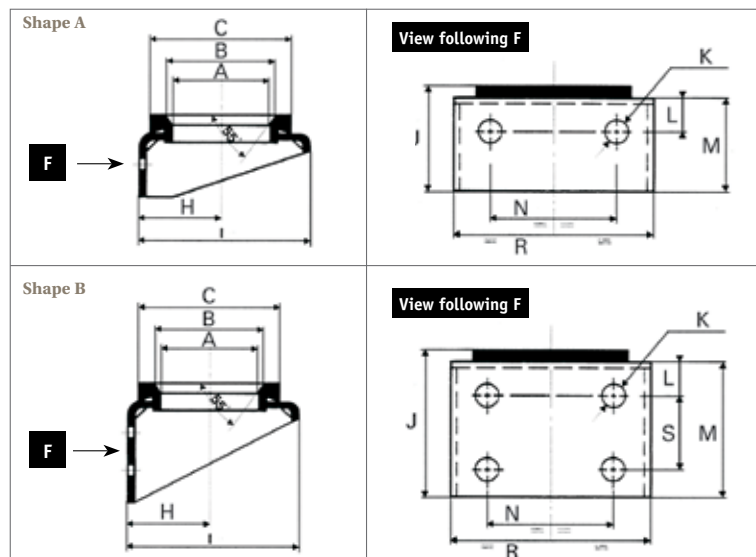

Above dimensions are in mm and are subject to manufacturing tolerances.

**Fittings**

Accumulator model	Connection of accumulator $\varnothing F$	Connection reducing bush $\varnothing l$ gas cyl.	J/Flats	K	O-Ring
EBV 0,5 to 5 L	G2" cyl.	1" Blind	65	13	54 x 3
EBV 10 to 50 L	G3 1/2" cyl.	2" Blind	112	20	96 x 4
EBV 100 to 575 L	M 205 x 3	2" Blind	2 opposite holes $\varnothing 8.5$	20	196.21 x 5.33

Other capacities consult Parker Olaer.

**Flanges**

Capacity of Accumulator	K	K
	PN 20 DN 40 1 1/2" ANSI 150 lbs	PN 50 DN 40 1 1/2" ANSI 300 lbs
EBV 0.5 to 5 L	22	25
EBV 10 to 50 L	28	37
EBV 100 to 575 L	142	151

Other capacities consult Parker Olaer.

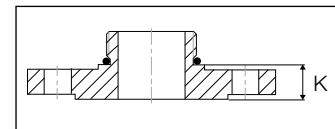
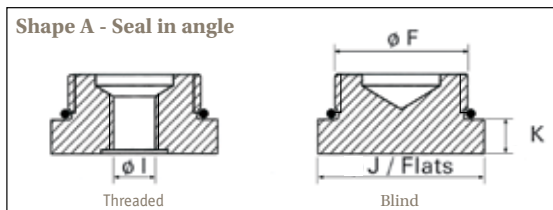

**Charging Sets**

The charging sets are an indispensable instrument for the verification, pressurization and nitrogen bleeding of most of the hydraulic accumulators available on the market. To use this unit, it is screwed on the gas charging valve of the accumulator and connected via a high pressure hose to the nitrogen source, equipped with a pressure regulator. If only the nitrogen pressure is to be controlled or reduced, this hose is not necessary.

**An Olaer pressure regulator - sold separately. It is mandatory to install a pressure regulator between the bottle or any nitrogen source and the charging set.**



**Model VG3**

The standard set is delivered in a storage case containing the following:

- pressure gauge with standardized graduations in bar
- vent valve
- 3 connection adaptors for charging valves. (7/8" - 5/8" - 8V1).
- High pressure hose, 2.5 m length, in standard, maximum working pressure 400 Bar. This hose is fitted at each end with a female swivel coupling G 1/4" BSP for connecting to the inflation port. It can be connected to a commercial nitrogen bottles, in this case add an adapter on one end view model in the country. For the other destinations consult Parker Olaer.
- Operating instruction french/english version

**Note:** On request, the following options are available :

- Pressure gauge with different scale divisions : 63 mm with glycerol bath back end G1/4" BSP equipped with direct gear for Minimess® connection. To scale divisions 0-10,0-60 with accuracy class 1.6%.
- High pressure hose of different length with adaptors for nitrogen bottles from various countries are available (specify country)



**Model VGU**

The standard set is delivered in a storage case containing the following:

- VGU universal tester and pressurizer (end M28 x 1.50).
- Pressure gauge kit from 0 to 25 bar.
- Pressure gauge kit from 0 to 250 bar.
- Connection adaptors for inflation valves (7/8" - 5/8" - 8V1 - M28 x 1.50).
- High pressure hose, 2.5 m long, for connecting to a nitrogen source.
- Hexagon socket screw key 6 mm.
- Jackets of replacement joints.
- Operating instruction in French, English, German.

**Note:** On request, the following options are available:

- Pressure gauge kits with different scale divisions: 63mm with glycerol bath back end G1/4" cyl. equipped with direct gear for Minimess® connection. Scale divisions 0-10, 0-60 with accuracy class 1.6%.
- High pressure hose of different length with adaptors for nitrogen bottles from various countries (specify country), at each end with a female swivel coupling G1/4" for connecting to the inflation port.

**Maximum working pressure: Maximum charging pressure: 20 bars for the EBV range.**





# How to order?

Series	Volume	Max. working pressure (PS)	Regulation code	Construction	Nitrogen gas precharge	Connection to be specified
<b>EBV</b>	<b>100</b>	<b>40</b>	<b>/90</b>	<b>01125</b>	<b>Po=5b</b>	<b>PN40-DN200</b>

EBV : Low pressure bladder accumulator

in litres

in Bar

00 : According to the PED, article 3.3 for the 0.5 L and 1 L volume  
 90 : According to the PED for all other volumes  
 Others : consult page 11

to be specified as per following recommendations table

Fluid	Working Temperature °C*	Construction
Mineral oils	- 15 + 100	01125
Water	0 + 60	03325
Diesel fuel (Gas Oil)	- 5 + 115	01130
Fuel Oil	- 5 + 115	01130
Kerosene	- 5 + 115	01130
Gasoline	- 5 + 115	01130
Lead free gasoline	- 20 + 130	01180
Other fluids	Other temperatures	Please contact Parker Olaer

\* standard construction

in Bar at 20 °C, limited to 20 Bar maximum at the maximum working temperature

Blind: with blind connector or with reduction connector (refer to dimension I on the overall dimensions page 8 and specify the connection) or with flange (refer to the flange line on the dimensions page 8 and specify the type).

## ORDERING THE ELG ACCUMULATOR

State the designation of the ELG accumulators mentioned in the table in page 4 “plumbing” (other constructions on request)

**Nitrogen gas pressure** in bar at 20 °C, limited to **20 bar maximum** at maximum working temperature. Refer to the plumbing sector section.

## ORDERING ACCESSORIES AND PERIPHERAL MATERIALS

Indicate the designation of accessories mentioned in the tables in pages 5 and 6 and the accessories on page 7 and 8.

## HOW TO ORDER THE REPAIR KIT

Example: For an EBV accumulator 100-40/90 01180  
 KIT EBV 100-40/90 01180

Item	Spare parts
1	Spare Parts Kit
2*	Bladder Assembly
3*	Gas valve
4*	Valve cap
5*	Snap ring
6*	Sealing ring
7*	Bushing assembly

\* These components are delivered in the spare parts kit

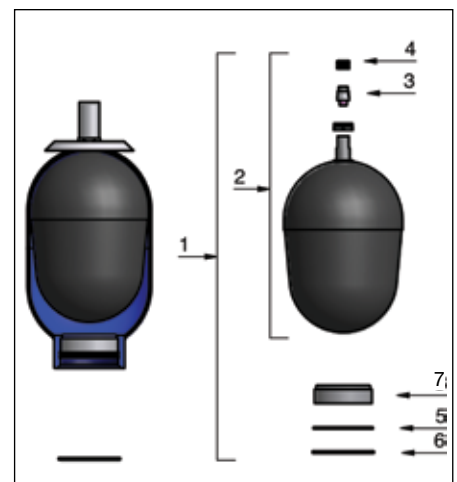

# Regulations

## Codification Table

Destination	Regulation	Parker Olaer Regulation Code	Comments	
Europe	CE	90	-	Approval is based on the directive PED 97/23/CE rules. The CE marking will be apposed on the product for Pressure Vessel risk category >= L.
USA	ASME	15	Based on ASME VIII div 1 without appendix 22	This regulation is based on the design code ASME VIII div 1. The Appendix 22 defines special requirements for the case of integrally forged pressure vessels.
		48	Based on ASME VIII div 1 with appendix 22	
China	SELO	88	Based on CE	This regulation is only applicable for pressure vessels which maximum working pressure $\geq 0.1$ MPa and maximum working pressure (Mpa) X volume (L) $\leq 2.5$ MPa.L.
Canada	CRN	92	Based on ASME VIII div 1 app 22	Approval is based on ASME VIII div 1 design code. Others countries as example Alaska require a CRN registration. Also, each province and territoire of Canada has its own CRN rules. So, thank you to indicate the concerned province for quotation.
Australia	AS1210	83	Based on CE	Australian regulation is applicable for pressure vessels which maximum working pressure (MPa) X volume (internal volume in L) $\geq 30$ Mpa.L in size.
		91	Based on ASME VIII div 1 app 22	
Japan	JIS	95	Based on ASME VIII div 1 app 22	Approval is based on ASME VIII div 1 design code (version 1998) and taking into account specific corrosion allowance value. JIS is applicable only for pressure vessels which internal diameter is higher than six inches.
Brasil	NR13	AA	Based on CE (AD-2000)	NR13 regulation is only applicable for pressure vessels which maximum working pressure (KPa) x internal volume (m3) $\geq 8$ .
		AE	Based on ASME VIII div 1 app 22	Also, technical documentation packaging must be established and joined to the equipment.
		AM	Based on CE (EN14359)	A special marking has to be done on the pressure vessel according to NR13 requirements.
Russia	GOST R	71	Based on CE	Certificate (CTR) must be established and joined to the equipment for delivery. Technical passport could be established if customer requires it.
		AU	Based on ASME VIII div 1 app 22	
Marine-Offshore	DNV	24	Based on CE	The marine and offshore applications have to respect some kind of classifications associated to third party (Notified body). This classification is often decided by the owner of the installation. All classification companies give almost the same approval process (design and manufacturing assessment). So, to see in details if the scope of these severals marine approvals are compatible with your application, please contact PARKER OLAER for accurate quotation.
	BUREAU VERITAS MARINE	11		
	ABS	41		
	LLOYDS REGISTER SHIPPING	10		
	GERMANISHER LLOYDS	73	-	
	RINA	26	Based on CE	
	DRILLING SYSTEMS	-	-	
France	NUCLEAR	90	-	Approval is based on RCCM design code and dedicated only to France market. For other countries out of France, ASME III div 1 is more recognized for nuclear plant activities.
Europe & Asia	NUCLEAR	AZ	Based on ASME III div 1	Approval is based on ASME III division 1, mainly on subsection NC for components class 2.

\* For these specific regulations (and/or) if your destination is not mentioned in this table, please contact PARKER OLAER for further information.

### Multi-Regulations codification examples\*

Codification	Regulation
90 EX	CE+ATEX
94	CE+ASME
88	CE+SELO
86	CE+ASME+SELO

How to include the correct regulation in your order?

Accu denomination example:

EBV 20-40 /XX

\* For other regulations, please contact directly Parker Olaer.

# Approvals

This table is giving an indication of approval availability for EBV series. Availability is to confirmed for each approval, in particular the pressure rating and the allowable working temperatures.

Designation	EUROPE				USA		CHINA		BRASIL		RUSSIA	
	/90	/90	/90	Max. Working Pressure bar	/15 /48	Max. Working Pressure Psi (bar)	/88	Max. Working Pressure bar	/AA /AE /AM	Max. Working Pressure bar	/71 /AU	Max. Working Pressure bar
Approvals	CE Fluid Group 2	CE Fluid Group 1	ATEXEX		ASME VIII div 1		SELO		NR13		GOST R	
Models												
EBV 0.5 L	x	x	x	40					x	40	on request	40
EBV 0.5 L	x	x	x	50					x	50		50
EBV 1 to 5 L	x	x	x	40			x	40	x	40		40
EBV 1 to 5 L	x	x	x	80			x	80	x	80		80
EBV 10 to 50 L	x	x		16					x	16		16
EBV 10 to 50 L	x	x	x	40	On request	580 (40)			x	40		40
EBV 100 to 200 L	x	x		16					x	16		16
EBV 100 to 200 L	x	x	x	20			x	20	x	20		20
EBV 100 to 200 L	x	x	x	40			x	40	x	40		40
EBV 100 to 200 L	x	x		50					x	50		50
EBV 100 to 575 L	x	x	x	8					x	8		8
EBV 100 to 575 L	x	x		10					x	10		10
EBV 100 to 575 L	x	x		15					x	15		15
EBV 100 to 575 L	x	x	x	16					x	16		16
EBV 100 to 575 L	x	x	x	20					x	20		20
EBV 100 to 575 L	x	x	x	40					x	40		40

## Installation

**Position:** Preferably vertical (liquid connection downwards) to horizontal, depending upon application. If the accumulator is installed in any position other than vertical with fluid port down, contact Parker Olaer. The accumulator could have reduced volumetric efficiency and Parker Olaer can help you to take these factors into account.

**Mounting:** A 200mm clearance is required above the accumulator to allow for gas charging. Each accumulator is delivered with a user instructions leaflet.

**Nitrogen gas pressure:** If not specified, the accumulator will be delivered with a storage pressure between 2 and 5 Bar.  
 Safety instruction : Never precharge accumulator at a precharge pressure exceeding **20 Bar** at maximum working temperature.



# Parker Worldwide

## Europe, Middle East, Africa

**AE – United Arab Emirates,**  
Dubai

Tel: +971 4 8127100  
parker.me@parker.com

**AT – Austria,** Wiener Neustadt

Tel: +43 (0)2622 23501-0  
parker.austria@parker.com

**AT – Eastern Europe,** Wiener  
Neustadt

Tel: +43 (0)2622 23501 900  
parker.easteurope@parker.com

**AZ – Azerbaijan,** Baku

Tel: +994 50 22 33 458  
parker.azerbaijan@parker.com

**BE/LU – Belgium,** Nivelles

Tel: +32 (0)67 280 900  
parker.belgium@parker.com

**BY – Belarus,** Minsk

Tel: +375 17 209 9399  
parker.belarus@parker.com

**CH – Switzerland,** Etoy

Tel: +41 (0)21 821 87 00  
parker.switzerland@parker.com

**CZ – Czech Republic,** Klecany

Tel: +420 284 083 111  
parker.czechrepublic@parker.com

**DE – Germany,** Kaarst

Tel: +49 (0)2131 4016 0  
parker.germany@parker.com

**DK – Denmark,** Ballerup

Tel: +45 43 56 04 00  
parker.denmark@parker.com

**ES – Spain,** Madrid

Tel: +34 902 330 001  
parker.spain@parker.com

**FI – Finland,** Vantaa

Tel: +358 (0)20 753 2500  
parker.finland@parker.com

**FR – France,** Contamine s/Arve

Tel: +33 (0)4 50 25 80 25  
parker.france@parker.com

**GR – Greece,** Athens

Tel: +30 210 933 6450  
parker.greece@parker.com

**HU – Hungary,** Budaoers

Tel: +36 23 885 470  
parker.hungary@parker.com

**IE – Ireland,** Dublin

Tel: +353 (0)1 466 6370  
parker.ireland@parker.com

**IT – Italy,** Corsico (MI)

Tel: +39 02 45 19 21  
parker.italy@parker.com

**KZ – Kazakhstan,** Almaty

Tel: +7 7273 561 000  
parker.easteurope@parker.com

**NL – The Netherlands,** Oldenzaal

Tel: +31 (0)541 585 000  
parker.nl@parker.com

**NO – Norway,** Asker

Tel: +47 66 75 34 00  
parker.norway@parker.com

**PL – Poland,** Warsaw

Tel: +48 (0)22 573 24 00  
parker.poland@parker.com

**PT – Portugal,** Leca da Palmeira

Tel: +351 22 999 7360  
parker.portugal@parker.com

**RO – Romania,** Bucharest

Tel: +40 21 252 1382  
parker.romania@parker.com

**RU – Russia,** Moscow

Tel: +7 495 645-2156  
parker.russia@parker.com

**SE – Sweden,** Spånga

Tel: +46 (0)8 59 79 50 00  
parker.sweden@parker.com

**SK – Slovakia,** Banská Bystrica

Tel: +421 484 162 252  
parker.slovakia@parker.com

**SL – Slovenia,** Novo Mesto

Tel: +386 7 337 6650  
parker.slovenia@parker.com

**TR – Turkey,** Istanbul

Tel: +90 216 4997081  
parker.turkey@parker.com

**UA – Ukraine,** Kiev

Tel +380 44 494 2731  
parker.ukraine@parker.com

**UK – United Kingdom,** Warwick

Tel: +44 (0)1926 317 878  
parker.uk@parker.com

**ZA – South Africa,** Kempton Park

Tel: +27 (0)11 961 0700  
parker.southafrica@parker.com

## North America

**CA – Canada,** Milton, Ontario

Tel: +1 905 693 3000

**US – USA,** Cleveland

(industrial)  
Tel: +1 216 896 3000

**US – USA,** Elk Grove Village

(mobile)  
Tel: +1 847 258 6200

## Asia Pacific

**AU – Australia,** Castle Hill

Tel: +61 (0)2-9634 7777

**CN – China,** Shanghai

Tel: +86 21 2899 5000

**HK – Hong Kong**

Tel: +852 2428 8008

**IN – India,** Mumbai

Tel: +91 22 6513 7081-85

**JP – Japan,** Fujisawa

Tel: +81 (0)4 6635 3050

**KR – South Korea,** Seoul

Tel: +82 2 559 0400

**MY – Malaysia,** Shah Alam

Tel: +60 3 7849 0800

**NZ – New Zealand,** Mt Wellington

Tel: +64 9 574 1744

**SG – Singapore**

Tel: +65 6887 6300

**TH – Thailand,** Bangkok

Tel: +662 717 8140

**TW – Taiwan,** Taipei

Tel: +886 2 2298 8987

## South America

**AR – Argentina,** Buenos Aires

Tel: +54 3327 44 4129

**BR – Brazil,** Cachoeirinha RS

Tel: +55 51 3470 9144

**CL – Chile,** Santiago

Tel: +56 2 623 1216

**MX – Mexico,** Apodaca

Tel: +52 81 8156 6000

### EMEA Product Information Centre

Free phone: 00 800 27 27 5374

(from AT, BE, CH, CZ, DE, DK, EE, ES, FI, FR, IE, IL,  
IS, IT, LU, MT, NL, NO, PL, PT, RU, SE, SK, UK, ZA)

### US Product Information Centre

Toll-free number: 1-800-27 27 537

www.parker.com

